

# FEDI® GIGA

Low Footprint, High Flow

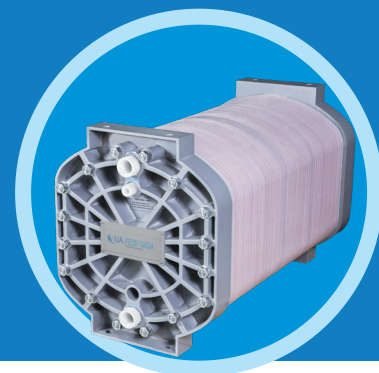

The QUA FEDI® GIGA is a next-generation fractional electrodeionization technology that is designed to produce ultrapure water with a high flow capacity while requiring a low footprint. It can minimize associated piping and instruments due to its unique port design feature that is one of the inlet and two outlet ports. It is the first electrodeionization stack with three ports—Feed, Product & Reject.

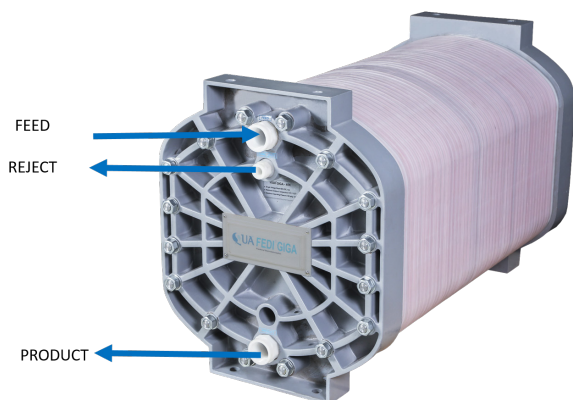

## FEATURES

- High flow per stack - up to 15 m<sup>3</sup>/hr (66 gpm)
- Minimum ports – Feed, Product & Reject
- Minimum piping & instrumentation
- Single voltage operation
- Ultrapure water quality
- Low footprint
- CE Certified, UL Certified 

## FEDI GIGA Specifications – STACK FLOWS

Parameters	Unit	30X	45X
Typical Product Flow	m <sup>3</sup> /hr	8*	12*
	gpm	35	53
Maximum Product Flow	m <sup>3</sup> /hr	10	15
	gpm	44	66
Minimum Product Flow	m <sup>3</sup> /hr	6	9
	gpm	27	40
Maximum Reject Flow	m <sup>3</sup> /hr	0.9	1.5
	gpm	4	6.6
Minimum Reject Flow	m <sup>3</sup> /hr	0.7	1.0
	gpm	3.1	4.4

\*Flow should be kept within these ranges for optimal performance

\*Depending upon feed water hardness, to be confirmed by FEDI Engineering Tool

## FEDI GIGA Specifications – FEED WATER

Parameters	Unit	Specifications
Feed Conductivity Equivalent (FCE) (with CO <sub>2</sub> ) *	µS/cm	<40
pH		6-9
Silica (Reactive)	ppm	< 1.0
Total Hardness as CaCO <sub>3</sub>	ppm	< 1.0
TOC	ppm	< 0.5
Heavy Metals (Fe,Mn etc)	ppm	< 0.01
Free Chlorine as Cl <sub>2</sub>	ppm	< 0.05
Feed Water SDI		< 1.0

\* Feed Conductivity Equivalent, FCE, (µS/cm) = Feed water conductivity (µS/cm) + ppm CO<sub>2</sub> x 2.83 + ppm SiO<sub>2</sub> x 2.0

## FEDI GIGA PRODUCT WATER SPECIFICATIONS

Parameters	Unit	Specifications
Product Resistivity	MΩ.cm	Up to 17
Silica (Reactive) Reduction	%	Up to 95

# FEDI® GIGA

Low Footprint, High Flow



## FEDI GIGA ELECTRICAL OPERATION

Parameters	Unit	30X	45X
Voltage Typical	VDC	250	350
Voltage Maximum	VDC	500	600
Current Typical	AMP	9	
Current Maximum	AMP	12	

## FEDI GIGA OPERATING CONDITIONS

Parameters	Unit	30X/45X
Recovery	%	≥ 90
Feed Water Temperature	°C °F	5 - 40 41 - 104
Pressure Drop (Feed to Product) @ Typical Flow	bar psi	1.4 - 2.0 20 - 30
Recommended Operating Pressure	bar psi	< 4.8 < 70
Maximum Feed Pressure	bar psi	7 100

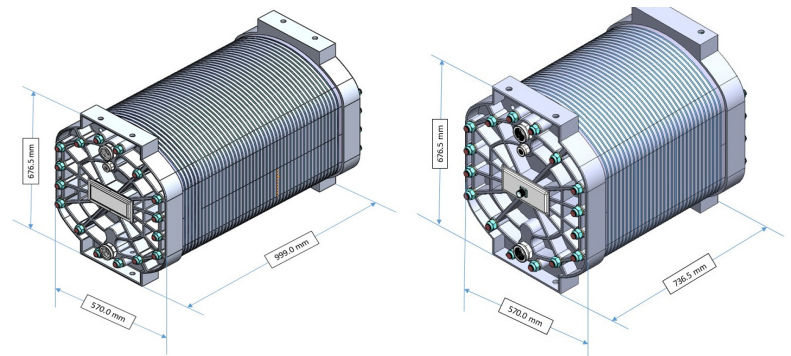

FEDI GIGA (45X)

FEDI GIGA (30X)

## FEDI GIGA STACK DIMENSIONS

Parameters	Unit	30X	45X
Weight (Per Stack)	Kg Lbs	280 617	350 772
Shipping Weight (Per Stack)	Kg Lbs	380 838	450 992
Length	mm inch	737 29.02	999 39.33
Width	mm inch	570 22.44	570 22.44
Height	mm inch	676.5 26.63	676.5 26.63



FEDI GIGA PORTS